



## Ecosy+ Hampton 6.4 Double Sided

### Installation and Operating Instructions



Version 1.1: 10/10/2019

## Wood-burning Stove

Model: Ecosy+ Hampton 6 Double Side

Dimensions:

465mm wide – 500mm deep – 530mm high

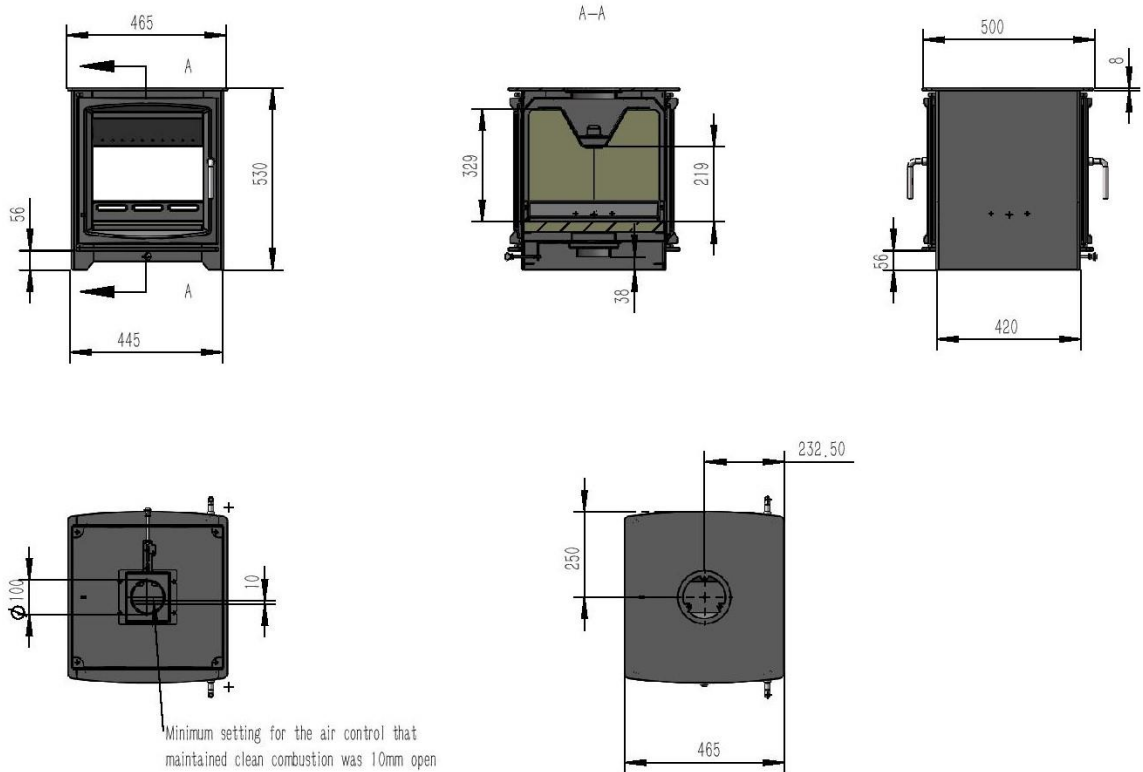

## SAFETY

Safety is the most important consideration when using and installing your stove. If not installed and used correctly, a house fire could result. Installation must comply with relevant national and local Building Regulations and fire safety standards.

IN THE EVENT OF A CHIMNEY FIRE, EVACUATE THE PROPERTY AND CALL THE EMERGENCY SERVICES.

Your stove will be heavy, and care needs to be taken when lifting - 2 people will normally be required to lift.

## UNPACKING

Your stove will have several of its components stored inside the stove itself for transportation. The main component is the flue collar; this will simply need attaching with the provided bolts. This is a Woodburning only stove, so does not require an ash pan or multi-fuel grate. All vermiculite fire bricks inside the stove must remain in place, these are not a part of the packaging.

## INSTALLATION

Installation of your stove must comply with relevant local and national Building Regulations and fire safety standards. We would always suggest using a qualified installer to carry out the installation of this product. The British recognised standard for solid fuel installations is HETAS. You can find a HETAS qualified installer in your area by going to the HETAS website – [www.hetas.co.uk](http://www.hetas.co.uk). If you are self-installing the stove must be signed off by the local authority.

## TECHNICAL

Hampton 6 Double Sided - Performance Test Results.

Weight	<b>104kg</b>
Total Efficiency (%)	<b>77.2</b>
Nominal heat output (KW)	<b>6.4</b>
Mean CO <sub>2</sub> emission (%)	<b>9.8</b>
Mean CO emission (%)	<b>0.10</b>
Mean CO emission (at 13 % O <sub>2</sub> ) (%)	<b>0.08</b>
Mean flue gas temperature (°C)	<b>299</b>
Flue gas mass flow (g/s)	<b>5.7</b>
Mean C <sub>n</sub> H <sub>m</sub> (at 13 % O <sub>2</sub> ) (Nmg/m <sup>3</sup> )	<b>73</b>
Mean NO <sub>x</sub> (at 13 % O <sub>2</sub> ) (Nmg/m <sup>3</sup> )	<b>118</b>
DIN Plus dust (at 13 % O <sub>2</sub> ) (Nmg/m <sup>3</sup> )	<b>28</b>

<b>Temperature Safety Test</b>	
Minimum distance to combustible material	
Side Wall – <b>450 mm</b>	
Maximum Hearth Temperatures:	
Directly under stove	<b>66°C ( Suitable for 12mm hearth )</b>
225mm in front of stove	<b>138°C</b>
300mm in front of stove	<b>128°C</b>
400mm in front of stove	<b>90°C</b>
<b>This stove is suitable for a 12mm hearth</b>	

#### All tests carried out at Kiwa Gastec UK

Your stove will require a constant air supply and should not be used at the same time and in the same room/space as extractor fans or any device which may draw air supply away from the stove unless the stove is taking air directly from the outside through a pipe connect to the 100mm outlet on the stoves base. The stove should be installed on a level floor with adequate load bearing capacity. The stove does include adjustable feet for levelling.

Normally for most houses in the UK no extra ventilation is required when installing a stove rated at 5kW or less.

Note: The requirements regarding ventilation have been updated in the most recent version of the Building Regulations and are now based on the air permeability of the house.

The stove is NOT suitable for installation in a shared flue system.

If installed in a standard type chimney, a register plate needs to be fitted inside the chimney.

When purchasing flexible flue liner, or twin walled flue, 6" diameter is required if the Defra stop is not fitted. If the Defra stop is in place a 5" liner or twin walled flue can be installed. It is against the law to install a 5" liner on a woodburning stove unless it has the required Defra fitting in place. The flue pipe must be fitted INSIDE the flue spigot and sealed with a generous amount of Fire Cement.

Access should be provided for cleaning the flue to ensure that the passageways for exhaust gases remain free from obstruction.

## OPERATING INSTRUCTIONS

### Regulations

All National and local regulations, including those referring to national and European standards, need to be complied with when installing the stove.

### **The Clean Air Act 1993 and Smoke Control Areas**

Under the Clean Air Act local authorities may declare the whole or part of the district of the authority to be a smoke control area. It is an offence to emit smoke from a chimney of a building, from a furnace or from any fixed boiler if located in a designated smoke control area. It is also an offence to acquire an “unauthorised fuel” for use within a smoke control area unless it is used in an “exempt” appliance (“exempted” from the controls which generally apply in the smoke control area).

In England appliances are exempted by publication on a list by the Secretary of State in accordance with changes made to sections 20 and 21 of the Clean Air Act 1993 by section 15 of the Deregulation Act 2015. Similarly, in Scotland appliances are exempted by publication on a list by Scottish Ministers under section 50 of the Regulatory Reform (Scotland) Act 2014. In Northern Ireland appliances are exempted by publication on a list by the Department of Agriculture, Environment and Rural Affairs under Section 16 of the Environmental Better regulation Act (Northern Ireland) 2016. In Wales appliances are exempted by regulations made by Welsh Ministers.

Further information on the requirements of the Clean Air Act can be found here:

<https://www.gov.uk/smoke-control-area-rules>

The Ecosy+ - Hampton 6.4 has been recommended as suitable for use in smoke control areas when burning seasoned wood logs. The appliance has a factory fitted modification stop to prevent closure of the secondary air inlet control rod beyond 10mm open.

Your local authority is responsible for implementing the Clean Air Act 1993 including designation and supervision of smoke control areas and you can contact them for details of Clean Air Act requirements.

Please note the following advice on minimising smoke emissions:

#### **Refuelling and Loading your Hampton 6 Double Sided**

1. When loading the stove we always suggest placing the logs in length ways ensuring the centre of the log is in line with the centre of the baffle plate. Loading the stove this way will ensure even burn of the logs by each side of the baffle. Please see below picture demonstrating how the logs should sit.



2. It is always important to load your stove at the correct time. If there is insufficient burning material in the fire bed to light a new fuel charge, excessive smoke emission can occur. Refuelling must be carried out onto a sufficient quantity of glowing embers and ash that the new fuel charge will ignite in a reasonable period. If there are too few embers in the fire bed, add suitable dry kindling to prevent excessive smoke. We also suggest not reloading when the stove is still “flaming”. Instead, allow the stove to burn down to hot embers before re charging the fire. Adopting this can reduce the risk of flames/smoke licking out of the stoves door if the chimney doesn’t have a strong enough pull to suck them around the baffle.
3. We suggest the door to be left ajar for around 3 minutes after each charge to give the next load of fuel an additional boost of air.

# FUEL

Wood- All types of wood are suitable provided they are well seasoned, UNTREATED, and have a moisture level between 12% and 20%. For soft woods, typically they will need to have been left in suitable storage for 9+ months for the moisture to evaporate. For hardwoods, this will usually be 18 months+. If you are unsure of the moisture content of your fuel, then you can buy a moisture meter which will indicate the moisture levels in your fuel. Liquid fuels must NEVER be used.

WARNING: Wet timber should not be used as this will create excess tar deposits in the chimney and stove and could increase the risk of chimney fire. Timber which is not of a suitable moisture content will also create more smoke and harmful emissions, and will damage the stove and flue system.

# AIR INLET CONTROLS

Base lever – The Hampton only has one control, on one face of the fire and this controls the Secondary/Airwash and Tertiary burn system all in one. Air is drawn through the base inlet and is fed over the fire through a series of holes on the baffle that stretches the width of the fire. This helps to burn off the initial smoke and gasses produced by the fire, prior to it going up the chimney. Air also flows past these holes between the twin layer of steel either side and is fed over the glass, helping it to keep clean and clear of smoke stains. When the lever is pulled towards you, more air is fed into the fire, pushed away from you decreases the amount of air into the fire.

When the Defra screw is activated this air vent is set such that the closure plate does not seal fully, thus allowing some constant air supply into the stove. This is a feature of all Defra “SE” stove

**Below image: For the stove to be compliant with Defra standards, this screw must be fully wound in. This is required if you are in a smoke free zone or want to install a 5” liner or chimney system**

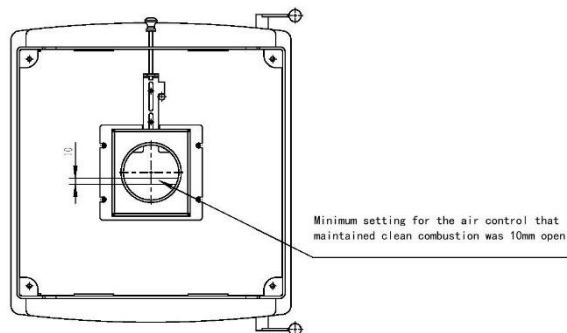

## TOOLS

The glove is provided for adjusting the air inlets and for opening the door when the stove is hot, as these knobs will heat up when in use. NOTE – all parts of the stove will become hot during use and care needs to be taken to avoid injury through burning.

## LIGHTING THE FIRE AND RE-FUELING

- ☑ Prior to lighting the fire for the first time, ensure that-
- ☑ Installation and building work is complete.
- ☑ The chimney is suitable and sound and has been swept and free from obstruction.
- ☑ Adequate ventilation and provision for combustion air has been made.
- ☑ That the stove installation has been carried out in accordance with Building Regulations and any applicable local regulations as well as these installation instructions.
- ☑ That chimney draw has been checked and within specification. (The stove has been tested at nominal output with a flue draught of 12 Pa)

ESSENTIAL INSTRUCTIONS BEFORE USE – It is essential to follow these ‘tempering-in’ instructions in order to avoid serious damage to your stove. The castings of your stove require very gentle ‘normalising’ to release stresses in the metal formed during the casting process. The paint finish also requires an initial curing process to be followed: -

For the initial tempering/ curing period, ensure the tertiary air inlet is set to MINIMUM, by pushing the lever to the left but ensuring it is not fully closed. For the first 2 burns on day one just use small controlled kindling wood fires with each fire lasting around 40 minutes – the second fire can be started when the stove is almost cooled down after the first. A third slightly hotter medium type fire should then be lit using smallish logs and lasting around 1 hour. Then for the next week or around 15-20 hours total burn time, fires must be gently increased in temperature and log size and load. A stove thermometer will be a valuable tool in helping you to achieve this safely and also to ensure an efficient burn rate in future. Starting a large fire too soon is likely to damage the stove in which case it will not be covered by the warranty. Note: the paint on any new stove is relatively soft. As such do not clean, wash or wipe the surface until the paint has fully cured. Never wipe the stove whilst warm. If the above advice is ignored, then there is a high risk of the paint being “shocked” by excessive heat and could peel. Furthermore, if the stove is over fired it will invalidate your guarantee.

ENSURE THAT YOU HAVE READ AND UNDERSTOOD THESE INSTRUCTIONS BEFORE LIGHTING THE FIRE, AND THAT YOU ARE CONFIDENT THE STOVE HAS BEEN INSTALLED CORRECTLY.

ALWAYS WEAR A PROTECTIVE GLOVE WHEN REFUELLING YOUR STOVE.

Ignition (FOLLOW INITIAL TEMPERING INSTRUCTIONS ABOVE FIRST TO AVOID DAMAGE)

- ☑ Construct a pile of kindling in the middle of the bed using approx 500g of kindling wood
- ☑ Light with a single chemical firelighter
- ☑ Partially shut the door but leaving it cracked open slightly
- ☑ After about 5 minutes or when the fire is well established, shut the door
- ☑ After a further 3-5 minutes as the fire starts to die, add a further three larger pieces of wood weighing approx. 0.75kg in total.



- ☒ Once these logs are alight, and after about 7 minutes or so, a normal load of 2 logs weighing up to 1.2kg in total can be added.
- ☒ Once this load is burning well the stove can be controlled with the lever

### **First use troubleshooting.**

When the stove is new the paint is very tacky where the stove is curing. The door locks very tight and when opened can pull away the fire rope from its chamber. If the instructions are followed above this should not happen. However, if it does the rope will need to be stuck back in place with “heat resistant fire rope glue” After a few burns the paint will be cured and this should no longer happen.

### **Refuelling**

**Every stove will work slightly differently depending on the chimney, or flue system it is attached to. It can take time to get use to the stove and how best to run and control it in each situation.**

- ☒ At nominal power output, your stove will require refuelling approximately every hour.
- ☒ It is important to follow these instructions in order to achieve clean burning and to maximise the efficiency of the stove
- ☒ Do not leave the fire unattended until flames are well established on the newly charged logs
- ☒ Always refuel onto hot embers.
- ☒ If the fire has died out at the point of refuelling, use kindling to re-establish the fire and follow the “Ignition” procedure above.
- ☒ It is important that the stove is not overloaded with fuel.
- ☒ Reduced burn rates can be achieved by reducing the openings of the Secondary and Tertiary air vents.
- ☒ Refuelling on to a low fire bed – If there is insufficient burning material in the firebed to light a new fuel charge, excessive smoke emission can occur.  
Refuelling must be carried out onto a sufficient quantity of glowing embers and ash that the new fuel charge will ignite in a reasonable period. If there are too few embers in the fire bed, add suitable kindling to prevent excessive smoke.
- ☒ Fuel overloading - The maximum amount of fuel specified in this manual should not be exceeded, overloading can cause excess smoke.
- ☒ Operation with door left open – Operation with the door open can cause excess smoke. The appliance must not be operated with the door left open except as directed in the instructions.
- ☒ Air controls left open  
Operation with the air controls or appliance dampers open can cause excess smoke. The appliance must not be operated with air controls, appliance dampers or door left open except as directed in the instructions.

**WARNING-** The high temperature paint covering the stove will give off some fumes during the initial few uses of the stove. The fumes are non-toxic, but some people may find them unpleasant – Ensure the area is well ventilated during this period.

Under certain abnormal weather conditions, e.g. down draughts, it may be difficult to get sufficient draw through the appliance to achieve good combustion. When this happens, the stove should not be used.

IMPORTANT: -

As of October 2010, it is a legal requirement to use a Carbon Monoxide Detector in the same room as the stove. This needs to incorporate a battery which lasts the life of the detector.

## CLEANING/MAINTENANCE

When cold, the inside of the stove should be given a regular sweep out.

The flue and flue pipe will require cleaning with a suitable chimney brush, to minimise build-up of soot and tar. Your chimney will also require periodic sweeping.

If the glass becomes stained from the inside, the air-wash vent may need opening more during use. The high temperature paint which your stove is finished in should last many years with normal use, but when it does eventually require re-finishing, black heat resistant paint in spray cans can be purchased from most hardware stores but we would suggest using "Calfire flat black paint". – Do not use regular paint which is not high temperature resistant. After prolonged periods of not using the fire, the stove and flue system should be checked for blockages prior to relighting. We recommend regular servicing and safety checks are carried out by a qualified engineer. There must be no unauthorised modification of the appliance. Use only replacement parts recommended by the manufacturer.

MODELS WITH MIRROR GLASS: THIS GLASS HAS A SPECIAL COATING, DO NOT USE ANY ABRASIVE MATERIAL TO CLEAN THE GLASS. Just use a clean cloth with warm water when the stove is cold, if you clean the glass when it is still warm the glass can "craze", crazing can also occur if incorrect fuels are burnt on the stove, or fuels with impurities in them. **If fire bricks have just split, they do not need replacing. The bricks only need replacing when they have fully crumbled away exposing the stoves rear or sides. Fire bricks are fully heat resistant but can easily split if struck with a log**

## GUARANTEE

The main body of your stove is guaranteed for 7 years.

Incorrect use or installation not carried out by a registered HETAS installer will void the guarantee. The only exceptions will be if the install has been signed off by your local authority or suitably qualified Oftec installer. In addition to this the stove must be serviced annually by a suitably accredited chimney sweep or stove installer. For example, HETAS / METAC / NACS. In this service any perishable parts that are damaged will need replacing. Please keep hold of these receipts, as they will most likely be required in an unlikely event that a claim was to be made. We will only ever be liable for the stove itself and will not cover the cost of installation or de-installation of a product. We urge customers to check the stove over prior to it being installed to double check there is no courier damage or obvious defects with the stove. Any potential Issues are easier to resolve before the stove is installed.

Notes:

If a fire brick is only split but is still fully protecting the shell, then it does not always need replacing in the service. They only need replacing when they have crumbled away, exposing the stove's shell.

If the seal is leaking air into the fire this does need changing right away. Any excess air could cause the burner to over fire. In some cases, the rope is fine, and the handle simply needs adjusting to make the door lock a little tighter. If the glass is not split and is only crazed, then it does not need replacing to keep in line with the guaranteed terms. Please keep a record of all services as this will be required if a claim is ever put forward. As a company we will only ever be responsible for the product itself and would not cover installation / de-installation of any product that did have to be replaced.

The guarantee period will begin when the stove has been invoiced. Please keep hold of your invoice as this will be requested if a claim is started. If this is not provided upon request, we will not be able to escalate your claim. The guarantee will begin from the sale date on the invoice, and we do not cover any cost incurred when removing faulty appliances or installing new ones, even if it has been proven that the stove is faulty. For full guarantee details please visit [www.ecosystoves.co.uk](http://www.ecosystoves.co.uk). With every claim we will require a signed copy of the sign-off sheet.

### **BROKEN FIRE BRICKS**

It is common for vermiculite bricks to break. They are fully heat resistant but can be quite fragile. The most common bricks to break are the base and back bricks as these take the brunt of abuse. To ensure the longevity of your fire bricks, please ensure that you gently place fuel in the fire and do not over stack fuel. We would also suggest leaving a small bed of ash in the fire at all times. This helps the wood burn more efficiently and also acts as a cushion between the log and the brick itself. If a brick is split it will not need replacing and this could potentially happen at any point. We only suggest changing bricks when they have crumbled away, exposing the stove's body.

### **BROKEN / CRAZED GLASS**

The glass used in all fires is fully approved heat resistant ceramic glass. This glass will not break through heat but can easily break if struck with a log or similarly hard object. This is why the glass is not covered by any manufacturer of stoves. Common causes for glass breakages are customers closing the door when a log is still sticking out. Glass will not always break straight away and can be chipped or weakened. It will then often break at a different time with seemingly no contact. When replacing glass, ensure you only pinch up the glass clips. If they are over-tightened it could cause the glass to break. Cloudy, 'milky' or crazed glass is caused by unburned acidic condensates etching the ceramic glass and unfortunately this cannot be easily removed. It is definitely not faulty glass but instead does have more to do with the quality of the fuel that you burn and the way that you operate your stove (long slumbering). This is less common on wood-only models as it is often caused by the high sulfur content in some coals. It is, however, possible. If your glass is crazed, it does not need changing and is safe to use.

### **Rusty Stove**

All stoves on the market are either made from mild steel or cast iron. The mild steel models like this are shot blasted and then painted with high temperature black paint. This will protect the stove but if the stove remains damp or wet for a long time the oxidization process ( surface rusting ) will begin.

Over time, if your stove begins to develop rust it will either be caused by:

- The stove being kept in a damp environment – For example if the stove was left in a damp place for a long time prior to fitting.

Or, the stove is in a damp room and not lit too often.

- The chimney is leaking water onto the stove.
- The stove is being cleaned with a wet cloth and not dried quickly.

Luckily, the resolution for this is not too hard. In most cases the stove will just need a wipe down with a dry cloth and touching up with some Calfire Flatt black paint. This will bring the paint back to a nice finish and will not reappear, assuming the cause of the stove getting damp / wet has been rectified.

Please see the below attached picture as an example for a stove that is beginning to rust.

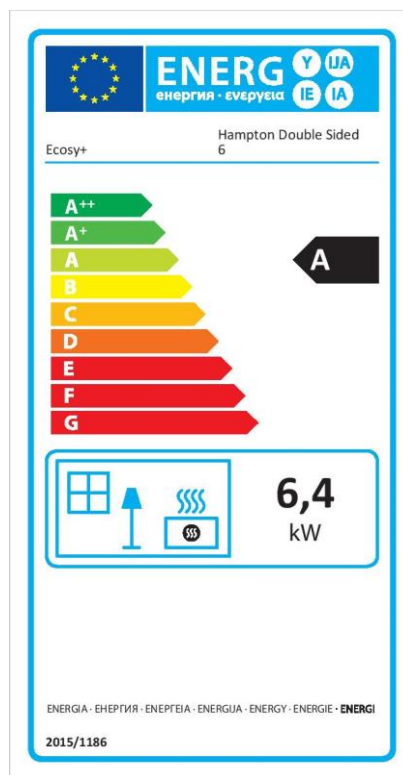

-Ecosy+, Unit 22-26 – Folly farm, Ramsdell, Tadley, RG26 5GJ

