

Rock 5 LANDSCAPE

Technical Information covering Rock 5 Landscape model-

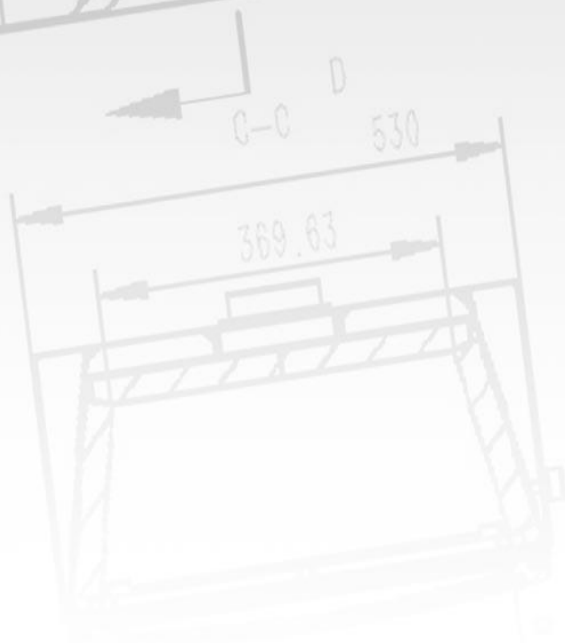

ADDRESS

Ecosy+
Unit 24, Folly Farm, Ramsdell
Tadley, Hampshire
RG26 5RJ
United Kingdom

CONTACT

Telephone: + 44 1256 830099
Email: trade@ecosystoves.co.uk

Brought to you by

Ecosy+ Stoves, Hampshire

CONTENTS

WELCOME	2
SAFETY	2
TECHNICAL INFORMATION COVERING SIGNATURE 5 AND SIGNATURE 5 LANDSCAPE	3
Rock 5 Landscape Drawing	4
ASSEMBLY	5
FLUE OUTLET	5
FLEGS	5
HEARTH.....	6/7
AIR SUPPLY / VENTILATION / CHIMNEY DRAW	8
CHIMNEY LINING	8
AIR CONTROL.....	9
FUEL OVERLOADING	9
SMOKE FREE ZONES	10
REGULATIONS.....	10
THE CLEAN AIR ACT 1993 AND SMOKE CONTROL AREAS	10
FUEL.....	11
LIGHTING MY STOVE	12
ESSENTIAL INSTRUCTIONS BEFORE USE.....	12
IGNITION	12
FIRST USE TROUBLESHOOTING	13
CLEANING AND MAINTENANCE	14
Baffle Plate Removal	14
Replacing the Fire Rope.....	14
Changing glass.....	14
GUARANTEE	15
BROKEN FIRE BRICKS	16
BROKEN / CRAZED GLASS	17
ENERGY EFFICIENCY	18

WELCOME

DEAR CUSTOMER,

Congratulations and thank you for purchasing a Rock 5 Landscape stove.

The Rock range of stoves are constructed from extremely thick cast iron and are very durable. Many cast stoves are often primitive in design, but this advanced unit has aced the Eco Design and Defra testing, meaning you have a classic fully cast stove with modern, highly reactive air system s

To top it off they are backed up with a 3-year promise.

To ensure you get the most out of your fire for the longest time, please take the time to have a read through the attached manual.

Yours Truly,

THE ECOSY+ TEAM

SAFETY

THIS STOVE IS APPROVED FOR BURNING BOTH WOOD AND SMOKELESS FUELS

To use any fuel will invalidate the guarantee.

IN THE EVENT OF A CHIMNEY FIRE, EVACUATE THE PROPERTY AND CALL THE EMERGENCY SERVICES.

INSTALLATION AND USE

Safety is the most important consideration when using and installing your stove. If not installed and used correctly, a house fire could result. Installation must comply with relevant national and local building regulations and fire safety standards.

Your stove will be heavy, (As expected with the name "Rock") and care needs to be taken when lifting - 2 people will normally be required to lift.

TECHNICAL INFORMATION – Rock 5 Landscape Stove

ROCK 5	
Outlet Size	5"
Defra Approved	Yes
Nominal Output	5kw
Efficiency	79.3% Wood / 79.8% Smokeless fuel
DIN Plus Dust (at 13% O2)	22 Wood / 22 Smokeless fuel
Mean NOX (at 13% O2)	104 Wood / 111 Smokeless fuel
Mean CnHm (at 13% O2)	40 Wood / 34 Smokeless fuel
Mean CO emissions	0.10 Wood / 0.12 Smokeless fuel
Hearth Temperature	37c
Flue gas mass flow g/s	4.9 Wood / 3.7 Smokeless fuel
Mean Flue Gas Temp	243 Wood / 251 Smokeless fuel
Distance to Combustibles at the Rear	750mm
Distance to Combustibles at the Side	600mm
ClearSkies Approved	Yes
Adjustable Feet	Yes

Rock 5 Landscape Drawing

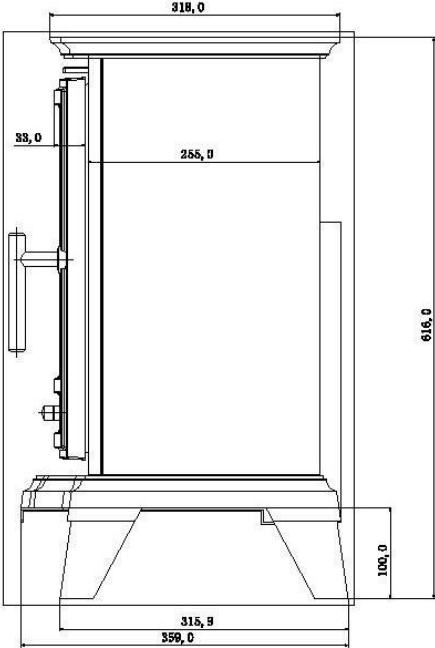
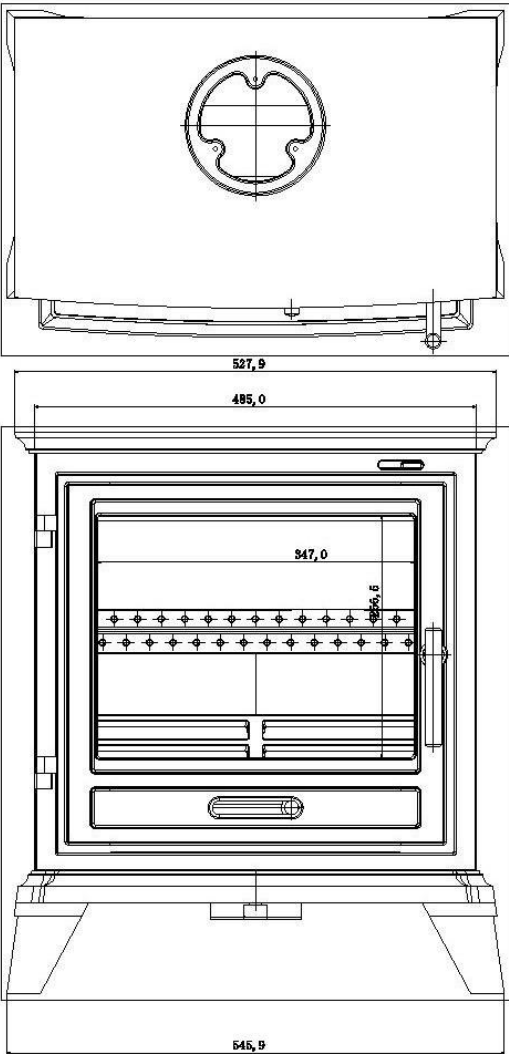

ASSEMBLY

Your stove is fully built and almost ready to go. All you need to is attach the legs and flue collar.

FLUE OUTLET

The Rock 5 has a top and rear flue outlet and will arrive with a set of threads. When securing the flue collar or blanking plate, ensure the screws are pinched up and not over-tightened.

LEGS

Your fire will arrive with the legs off and inside the fire. This is done to prevent damage in transit. Bolts will be provided and the legs must be attached to the stove. This fire cannot be used with the stove sat directly on the hearth.

HEARTH

The whole Rock range is suitable for a 12mm free standing, non-constructional hearths - see diagram below, marked (b). This is allowed because each model's base does not exceed 100°C. The hearth must be made from a non-combustible material strong enough to stand the weight of the fire. Further diagrams relating to constructional hearths are attached below.

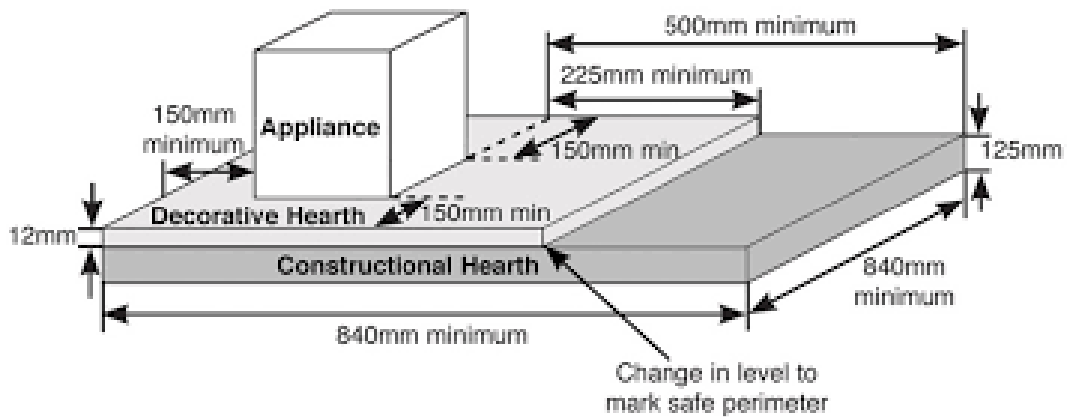
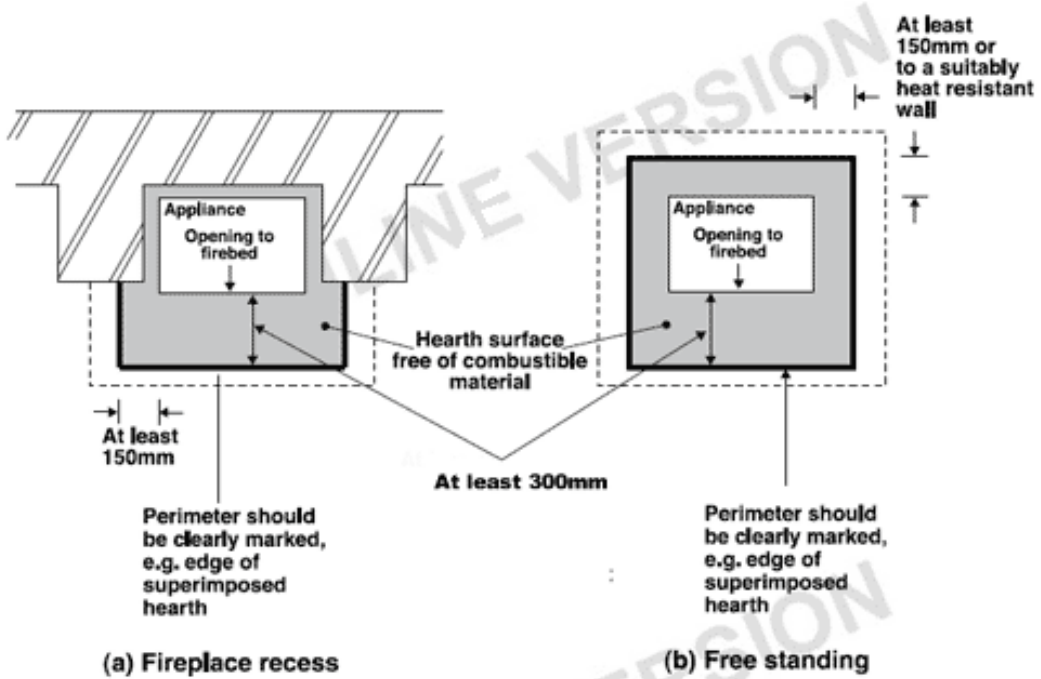

Section through hearth

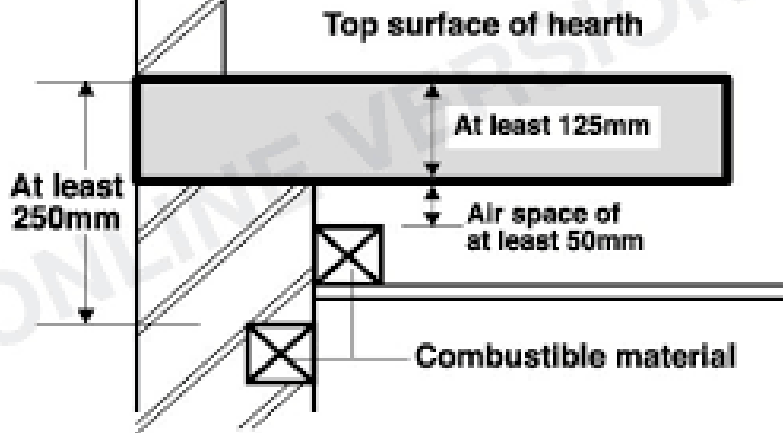

AIR SUPPLY / VENTILATION / CHIMNEY DRAW

Your stove will require a constant air supply and should not be used at the same time and in the same room/space as extractor fans or any device which may draw air supply away from the stove. Note: The requirements regarding ventilation have been updated in the most recent version of the Building Regulations and are now based on the air permeability of the house. Any stove being installed in a home that has permeability ratings of 5 m³/hm² or less will require ventilation irrespective of the KW output.

If you find the stove draws well with the door ajar but often dies when the door is closed, it could be caused by a lack of oxygen able to flow through the air inlets. A common cause for this is a lack of free oxygen in the room and additional ventilation may be required.

The testing for this model has been carried out on a chimney with a rating of 12 Pascals and this is industry standard. Anything less than this approved rating could cause smoke to spill from the stove into the room. The chimney is often overlooked by the end user but has a huge bearing on how the fire will perform. The chimney creates suction that pulls the smoke up the chimney and out, opposed to forcing it out of the fire and into the room. The most common cause for a chimney not performing well is the fact it is cold. Cold air sinks the smoke down, whereas a warmer chimney draws the smoke up and out. This issue is most common on twin-walled chimney systems and exposed brick chimneys on the gable end of a house. Getting heat up the chimney as quickly as possible will help to ensure this negative pressure is reversed as quickly as possible. The minimum chimney height required for this unit is 4.5 meters. The complete system must have fewer than 4 bends and each bend should be 45 degrees or under. You can exit from the rear of the fire and attach our custom rear flue box or a 90-degree T piece. Ensure single skin flue pipe is kept away from combustible materials as this will get very hot.

If you are installing into a brick chimney, we would suggest lining the chimney with an approved flexible liner. (316 or 904 grade) Doing so will increase the stove efficiency. Do not connect or share the flue or chimney.

CHIMNEY LINING

When purchasing flexible flue liner, or twin walled flue, 6" diameter is required if the Defra stop is not fitted. If the Defra stop is in place a 5" liner or twin-walled flue can be installed. It is against the law to install a 5" liner on a woodburning stove unless it has the required Defra fitting in place. The flue pipe must be fitted INSIDE the flue spigot and sealed with a generous amount of Fire Cement. Access should be provided for cleaning the flue to ensure that the passageways for exhaust gases remain free from obstruction. This stove cannot be installed into a shared flue.

AIR CONTROL

The Rock range has 3 separate air controls.

1. **Primary Air:** This is the small control on the door, just below the pane of glass. When slid to the right, air is flowing in and slid to the left air is restricted. Primary air is predominantly required when burning smokeless fuel, as smokeless fuel requires ample primary air under the grate to sustain a good burn. On all fuels this should be open to begin with but closed relatively quick if wood is being burnt. Wood does not require a great deal of primary air.
2. **Air wash / Tertiary:** This is the control just above the door in the top right corner. When slid to the right, air is flowing in and slid to the left air is restricted. This control manages the air flowing over the glass and helps to keep it clean and clear of smoke stains. To begin with this will need to be left open. When the fire has become established and hot, this can slowly be closed. In many cases to prevent the glass from going black a small gap will be required.
3. **Secondary Air:** This is the control under the fire. When pulled towards you, this vent is opened and when pushed away this vent is closed. This controls the air flowing through the series of holes at the back of the fire and will be the main control used for the burning of wood. To begin with this will need to be left fully open. When the fire is hot and established this can slowly be closed off and adjusted accordingly when required.

When you light the fire, you will want all vents fully open and in most cases the door ajar slightly. However, this will depend on how well the chimney is drawing. When the fire is established to some degree the door can be closed and the vents gradually closed. If you close the vent down too early before the fire is established, it could go out and/or increase smoke output. When the stove is burning hot and is well established you can turn the fire right down. If done at the right time and with the right fuel, it will die right back and gently burn away for a long time.

When you come to refuel, if there is insufficient burning material in the fire bed to light a new fuel charge, excessive smoke emission can occur. Refueling must be carried out onto a sufficient quantity of glowing embers and ash that the new fuel charge will ignite in a

TIPS

If you find the glass or fire bricks are going black even when the fire is established, it is most likely caused by burning wet wood. When burning dry wood, the fire bricks and glass should remain largely clean.

FUEL OVERLOADING

The maximum amount of fuel specified in this manual should not be exceeded. Overloading can cause excess smoke.

SMOKE FREE ZONES

REGULATIONS

All National and local regulations, including those referring to national and European standards, need to be complied with when installing the stove.

THE CLEAN AIR ACT 1993 AND SMOKE CONTROL AREAS

Under the Clean Air Act local authorities may declare the whole or part of the district of the authority to be a smoke control area. It is an offence to emit smoke from a chimney of a building, from a furnace or from any fixed boiler if located in a designated smoke control area. It is also an offence to acquire an “unauthorised fuel” for use within a smoke control area unless it is used in an “exempt” appliance (“exempted” from the controls which generally apply in the smoke control area).

In England appliances are exempted by publication on a list by the Secretary of State in accordance with changes made to sections 20 and 21 of the Clean Air Act 1993 by section 15 of the Deregulation Act 2015. Similarly, in Scotland appliances are exempted by publication on a list by Scottish Ministers under section 50 of the Regulatory Reform (Scotland) Act 2014. In Northern Ireland appliances are exempted by publication on a list by the Department of Agriculture, Environment and Rural Affairs under Section 16 of the Environmental Better regulation Act (Northern Ireland) 2016. In Wales appliances are exempted by regulations made by Welsh Ministers.

Further information on the requirements of the Clean Air Act can be found here:

<https://www.gov.uk/smoke-control-area-rules>

The Rock range has been recommended as suitable for use in smoke control areas when burning seasoned wood logs. Each appliance has been factory fitted with a screw that prevents the full closure of the vent. In a smoke control area the air control stop must be fitted. If this is removed, then the stove will no longer be exempt and therefore no longer suitable for burning unauthorised fuels in a smoke control area.

Your local authority is responsible for implementing the Clean Air Act 1993 including designation and supervision of smoke control areas and you can contact them for details of Clean Air Act requirements.

Please see below pictures. These demonstrates the permanent gaps required for the stove to comply with the above recommendations

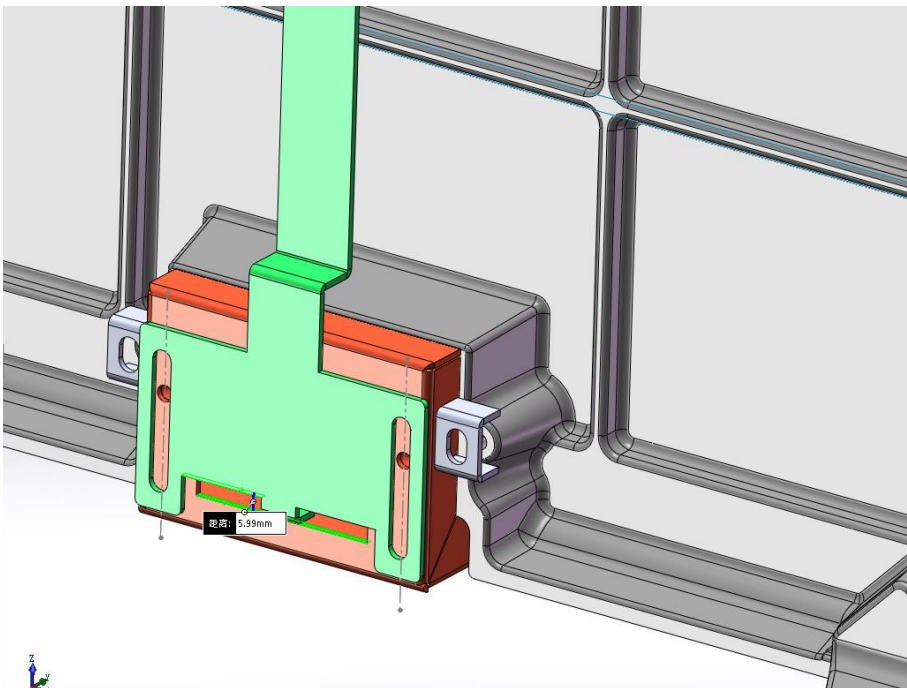

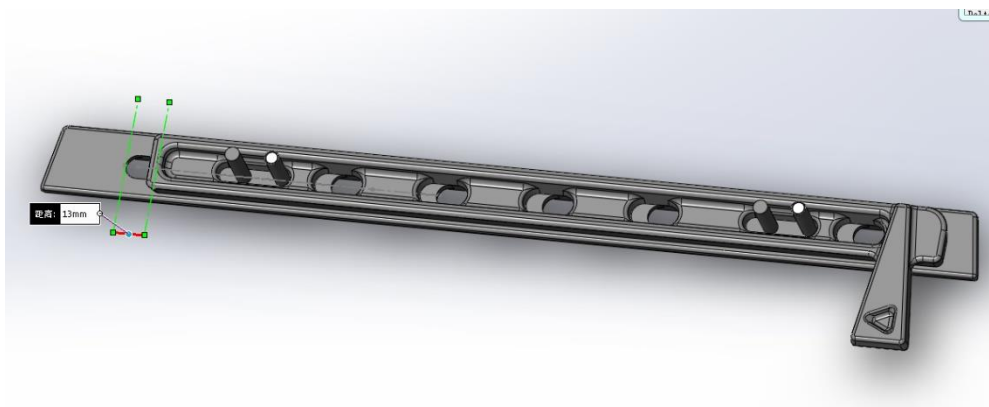

Please note the following advice on minimising smoke emissions:

FUEL

Wood- All types of wood are suitable provided they are well seasoned, UNTREATED, and have a moisture level between 12% and 20%. For soft woods, typically they will need to have been left in suitable storage for 9+ months for the moisture to evaporate. For hardwoods, this will usually be 18 months+. It is recommended that logs should be no more than 5” (125mm) in diameter and 8” (200mm) in length. If you are unsure of the moisture content of your fuel, then you can buy a moisture meter which will indicate the moisture levels in your fuel. Liquid fuels must NEVER be used.

WARNING: Wet timber should not be used as this will create excess tar deposits in the chimney and stove and could increase the risk of chimney fire. Timber which is not of a suitable moisture content will also create more smoke and harmful emissions and will damage the stove and flue system. If you are buying wood, always look out for the “Ready To Burn” logo. Suppliers who sign up to this have regular checks to ensure that the wood they are selling is below a certain moisture content and is consistent with what they are advertising.

Solid Fuel – Solid mineral fuel should be placed in the stove so that there is no more than a 30° incline of the fuel bed from front to back. It should not be stacked above the level of the rear firebrick as this may result in damage to the stove. Always de-ash before refueling and do not let the ash build up to the underside of the grate. Solid mineral fuel produces ash, which if allowed to build up will stifle the airflow through the Primary air inlet. This will eventually cause the fire to go out. With some solid mineral fuels, a residue of burnt fuel or clinker will accumulate on the grate. Allow the fire to go out periodically to remove this. Important! - We cannot stress firmly enough how important it is to empty the ashpan regularly. Air passing through the fire bed cools the grate down. Distortion or burning out the grate bars is nearly always caused by ash being allowed to build up to the underside of the grate. Anthracite is an approved natural smokeless fuel (not processed) and therefore can vary greatly in quality and performance. It generally requires excellent air supply and above average fire-bed temperatures to maintain maximum performance and with experience we would suggest that it is used in conjunction with other approved manufactured smokeless fuels as per the HETAS approved list <http://www.hetas.co.uk/find-fuels/> . Smokeless fuels



LIGHTING MY STOVE

Prior to lighting the fire for the first time, ensure that

- Installation and building work is complete.
- The chimney is suitable and sound and has been swept and free from obstruction.
- Adequate ventilation and provision for combustion air has been made.
- The stove installation has been carried out in accordance with Building Regulations and any applicable local regulations as well as these installation instructions.
- Chimney draw has been checked and within specification. (The stove has been tested at nominal output with a flue draught of 12 Pa)

ESSENTIAL INSTRUCTIONS BEFORE USE

It is essential to follow these 'tempering-in' instructions in order to avoid serious damage to your stove. The castings of your stove require very gentle 'normalising' to release stresses in the metal formed during the casting process. The paint finish also requires an initial curing process to be followed and will release a smell when burning off: For the first few burns we suggest opening a window to get rid of the smell.

You will need to have at least two controlled small wood fires, each fire lasting around 40 minutes – the second fire can be started when the stove is almost cooled down. After these fires you can increase the fuel load but still control the fire for another few burns as the paint may still be curing and in a fragile state. Starting a large fire too soon is likely to damage the stove in which case it will not be covered by the warranty. Note: the paint on any new stove is relatively soft. As such do not clean, wash or wipe the surface until the paint has fully cured. Never wipe the stove whilst warm. If the above advice is ignored, then there is a high risk of the paint being "shocked" by excessive heat and could peel. Furthermore, if the stove is over fired it will invalidate your guarantee.

ENSURE THAT YOU HAVE READ AND UNDERSTOOD THESE INSTRUCTIONS BEFORE LIGHTING THE FIRE, AND THAT YOU ARE CONFIDENT. THE STOVE HAS BEEN INSTALLED CORRECTLY.

ALWAYS WEAR A PROTECTIVE GLOVE WHEN REFUELLING YOUR STOVE.

IGNITION

(FOLLOW INITIAL TEMPERING INSTRUCTIONS ABOVE FIRST TO AVOID DAMAGE)

- Construct a pile of kindling in the middle of the bed using approx 500g of kindling wood.
- Ensure all vents are open
- Light with a single firelighter.
- Leave the door ajar slightly as that begins to catch.
- After a few minutes' add your first log or two and then continue to leave the door ajar.
- When the burn becomes established you can close the door; from there, as the fire gains in momentum and the firebox increases in heat, you can begin closing the vents down.
- Once the load burns down to embers you can open the vents and re-load the fire.

TIPS

Getting heat into the chamber is very important. A hot chamber will increase the stoves efficiency and make refueling the fire very easy. If the temperature in the stove is too low, the glass will begin to go black and excess smoke will be produced. Often the key to a hot firebox is the burning of quality dry fuel.

FIRST USE TROUBLESHOOTING

When the stove is new the paint is very tacky where the stove is curing. The door locks very tightly and when opened can pull away the fire rope from its chamber. If the instructions are followed above this should not happen. However, if it does, the rope will need to be stuck back in place with “heat resistant fire rope glue” After a few burns the paint will be cured and this should no longer happen.

WARNING The high temperature paint covering the stove will give off some fumes during the initial few uses of the stove. The fumes are non-toxic, but some people may find them unpleasant. Ensure the area is well ventilated during this period

In some cases, you glass can go black in the first few burns. This happens because the stove is not running hot. When the stove gets up to temperature this should begin to burn off. If it does not, the glass may need cleaning with a stove glass cleaner or a damp cloth that has been dipped in the ash.

Under certain abnormal weather conditions, for example down draughts, it may be difficult to get sufficient draw through the appliance to achieve good combustion. When this happens, the stove should not be used.

Dampers left open

Operation with the air control or appliance dampers open can cause excess smoke. The appliance must not be operated with air controls, appliance dampers or door left open except as directed in the instructions.

Operation with door left open

Operation with the door open can cause excess smoke. The appliance must not be operated with the appliance door left open except as directed in the instructions.

CLEANING AND MAINTENANCE

When cold, the inside of the stove should be given a regular sweep out.

The flue and flue pipe will require cleaning with a suitable chimney brush, to minimise build-up of soot and tar. Your chimney will also require periodic sweeping. We would suggest using a registered and qualified chimney sweep. If the glass becomes stained from the inside, the air-wash vent may need opening more during use. The high temperature paint which your stove is finished in should last many years with normal use, but when it does eventually require re-finishing, black heat resistant paint in spray cans can be purchased from most hardware stores. We would suggest using "Calfire flat black paint". Do not use regular paint which is not high temperature resistant. After prolonged periods of not using the fire, the stove and flue system should be checked for blockages prior to relighting. We recommend regular servicing and safety checks are carried out by a qualified engineer. There must be no unauthorised modification of the appliance. Use only replacement parts recommended by the manufacturer.

Baffle Plate Removal

This model has a twin baffle design. The first being a vermiculite board. To remove this board, you will need to remove the side bricks and slowly drop the baffle onto the stoves grate. When removed you will come to the second baffle that is made from folded steel. This baffle is bolted in place and can be removed by undoing the two 10mm nuts that hold it in place.

Replacing the Fire Rope

If your fire rope has become frayed and is no longer making a good contact it will need replacing. To change the rope we suggest removing the door and laying it flat. To remove the door you need to lever up the bottom door pin, that will have a small head on it. When this is removed, the door will drop down and pull away. When removed you can pull away the old rope and clean out the groove, ensuring it is free of debris. Make a note of how the rope was laid as this will make laying the new rope easier. When the groove is clean, line it with a continuous bead of heat resistant rope glue. You can then lay the rope in the groove pressing it as you go and cutting off any excess. Allow at least 30 minutes for this to dry before re-attaching the door.

Changing glass

To change the glass, you will first need to remove the door. To do this you need to lever up the bottom door pin and this will have a small head on it. When this is removed, the door will drop down and pull away. When removed, lay down the door with the handle facing down. Begin removing the small glass clips. When removed you can take the old glass out and pop the new one in. When in place, ensure it is making good contact with the fire rope. If that has been checked, you can re-attach the clips and gently pinch them up. Overtightening these clips can cause the glass to break.

GUARANTEE

The main body of your stove is guaranteed for 3 years.

Incorrect use or installation not carried out by a registered HETAS installer will void the guarantee. The only exceptions will be if the install has been signed off by your local authority or suitably qualified Oftec installer. In addition to this the stove must be serviced annually by a suitably accredited chimney sweep or stove installer. For example, HETAS / METAC / NACS. In this service any perishable parts that are damaged will need replacing.

Please note, the guarantee *does not include* broken glass, crazed glass, fire bricks, door seals, paint as these are all classed as perishable items.



Notes:

If a fire brick is only split but is still fully protecting the shell, then it does **not** always need replacing in the service. They only need replacing when they have crumbled away, exposing the stove's shell.

If the seal is leaking air into the fire this does need changing right away. Any excess air could cause the burner to over fire. In some cases, the rope is fine and the handle simply needs adjusting to make the door lock a little tighter.

If the glass is not split and is only crazed then it does not need replacing to keep in line with the guarantee terms.

Please keep a record of all services as this will be required if a claim is ever put forward.

As a company we will only ever be responsible for the product itself and would not cover installation / de-installation of any product that did have to be replaced.

The guarantee period will begin when the stove has been invoiced. Please keep hold of your invoice as this will be requested if a claim is started. If this is not provided upon request, we will not be able to escalate your claim. The guarantee will begin from the sale date on the invoice and we do not cover any cost incurred when removing faulty appliances or installing new ones, even if it has been proven that the stove is faulty. For full guarantee details please visit www.ecosystoves.co.uk. With every claim we will require a signed copy of the sign-off sheet.

BROKEN FIRE BRICKS



It is common for vermiculite bricks to break. They are fully heat resistant but can be quite fragile.

The most common bricks to break are the base and back bricks as these take the brunt of abuse. To ensure the longevity of your fire bricks, please ensure that you gently place fuel in the fire and do not over stack fuel. We would also suggest leaving a small bed of ash in the fire at all times. This helps the wood burn more efficiently and also acts a cushion between the log and the brick itself. If a brick is split it will not need replacing and this could potentially happen at any point. We only suggest changing bricks when they have crumbled away, exposing the stove's body.

BROKEN / CRAZED GLASS

The glass used in all fires is fully approved heat resistant ceramic glass. This glass will not break through heat but can easily break if struck with a log or similarly hard object. This is why the glass is not covered by any manufacturer of stoves. Common causes for glass breakages are customers closing the door when a log is still sticking out. Glass will not always break straight away and can be chipped or weakened. It will then often break at a different time with seemingly no contact. When replacing glass, ensure you only pinch up the glass clips. If they are over-tightened it could cause the glass to break.

Cloudy, 'milky' or crazed glass is caused by unburned acidic condensates etching the ceramic glass and unfortunately this cannot be easily removed. It is definitely not faulty glass, but may have more to do with the quality of the fuel that you burn and the way that you operate your stove (long slumbering). This is less common on wood-only models as it is often caused by the high sulphur content in some coals. It is, however, possible. If your glass is crazed it does not need changing and is safe to use.



An example of crazed stove glass.

ENERGY EFFICIENCY

